



# Vinyl Railing

# STEP-BY-STEP INSTALLATION INSTRUCTIONS FOR KEYSTONE RAILING

Assembly for: Flat, Column, 45 Degree, 22-1/2 Degree, Stair

Virtually Maintenance free | Aluminum reinforced for added safety  
Complies with the International Residential Code (IRC) for one- and  
two-family dwellings | Lifetime Limited Warranty

## BEFORE YOU BEGIN

### HELPFUL HINTS

Read these instructions thoroughly before beginning the assembly.

- Use carbide-tipped multi-purpose blade for cutting.
- Do not lay vinyl components on abrasive surfaces.
- If any components are missing or defective, please call us at:  
**800-333-0569**

### TOOLS REQUIRED

- Chop/Mitre saw –  
with carbide tipped multi-purpose blade
- Drill and drill bits
- Tape measure
- Pencil
- Level

### TIPS

- Make sure you have all the pieces you need to complete the job.
- Separate your flat and stair pieces to avoid using the wrong ones.

### MOUNTING WITH POSTS SUPPORTED BY A STEEL SUPPORT KIT

Vinyl posts alone do not provide adequate fastener retention. You must provide a wood or composite block inside posts at bracket locations for proper fastener retention.

- Install EverNew concrete post support as directed
- After attaching EZ-set brackets to post support, set 5/4"x3-5/8"x6" blocks above bottom EZ-set bracket on both sides of post
- Slide vinyl post over blocks and EZ-set brackets
- Slide 5/4"x3-5/8"x6" blocks into post down to upper EZ-set bracket
- Install rails, balusters, and brackets. Be sure to screw brackets into areas reinforced by blocks.

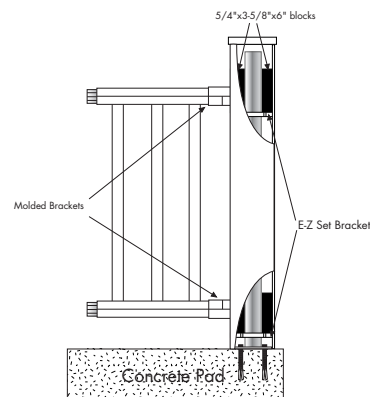

### IMPORTANT:

**ALWAYS WEAR SAFETY  
GLASSES WHEN CUTTING AND  
DRILLING VINYL/ALUMINUM  
RAILING PRODUCTS.**

# ASSEMBLY FOR 22½° AND 45°

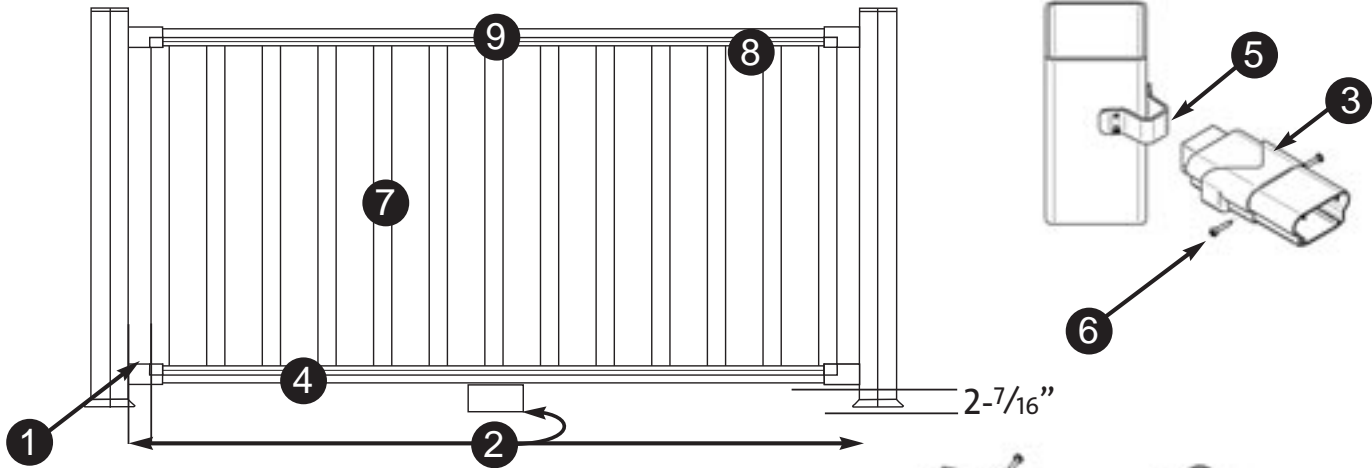

**NOTE:** Two brackets are required per section end.

**Important:** To ensure meeting code requirements, be sure that the space between the last baluster and the wall or post is not more than 4".

**Step 1:** Check for equal baluster spacing at posts. For 22-½° and 45°, mark rail where it meets post - do not measure back.

**Step 2:** Square rails and cut. Install crush block to bottom rail.

**Step 3:** Slide vinyl covers over ends of rails. Insert aluminum brackets into both ends of rails. Note: Vinyl cover can be field cut to avoid baluster interference.

**Step 4:** Position bottom rail between posts. For 22-½° and 45°, slide rail down inside corner of post.

**Step 5:** To secure aluminum bracket to posts with screws provided (two screws per aluminum bracket) on the TOP rail, place screws in the bottom holes of the bracket. On the BOTTOM rail, place screws in the top holes of the bracket. Slide vinyl covers to posts.

**Step 6:** Fasten cover and rail to aluminum bracket with 1" screws (provided) through flat sides of vinyl covers. (Tip - Pre-drilling rail and bracket will enhance application. Use a ⅝" drill bit).

**Step 7:** Insert balusters into bottom rail.

**Step 8:** Install top rail and repeat steps 5-6.

**Step 9:** For 10' railing, insert provided screws through flat side of top and bottom rails into middle baluster to secure midpoint of railing.

# ASSEMBLY FOR FLAT AND COLUMN

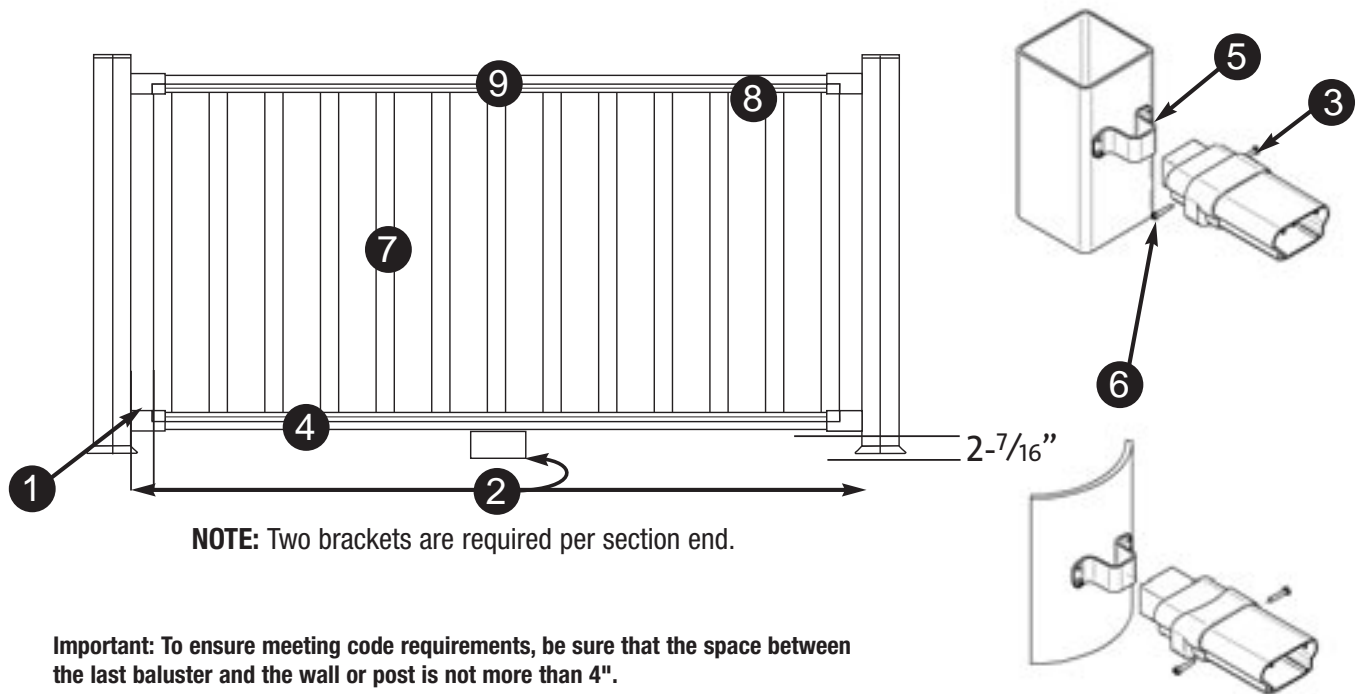

**Step 1:** Check for equal baluster spacing at posts. For flat and columns, mark rail where it meets the post. Measure back 1/4" from mark.

**Step 2:** Square rails and cut. Install crush block to bottom rail.

**Step 3:** Slide vinyl covers over ends of rails. Insert aluminum brackets into both ends of rails. Note: Vinyl cover can be field cut to avoid baluster interference.

**Step 4:** Position bottom rail between posts.

**Step 5:** To secure aluminum bracket to posts with screws provided (two screws per aluminum bracket) on

the TOP rail, place screws in the bottom holes of the bracket. On the BOTTOM rail, place screws in the top holes of the bracket. Slide vinyl covers to posts.

**Step 6:** Fasten cover and rail to aluminum bracket with 1" screws (provided) through flat sides of vinyl covers. (Tip - Pre-drilling rail and bracket will enhance application. Use a 9/64" drill bit).

Alternative flat installation: Secure rail to aluminum bracket first and then slide vinyl cover to post. Secure cover in place with vinyl adhesive.

**Step 7:** Insert balusters into bottom rail.

**Step 8:** Install top rail and repeat steps 5-6.

**Step 9:** For 10' railing, insert provided screws through flat side of top and bottom rails into middle baluster to secure midpoint of railing.

# STAIR ASSEMBLY

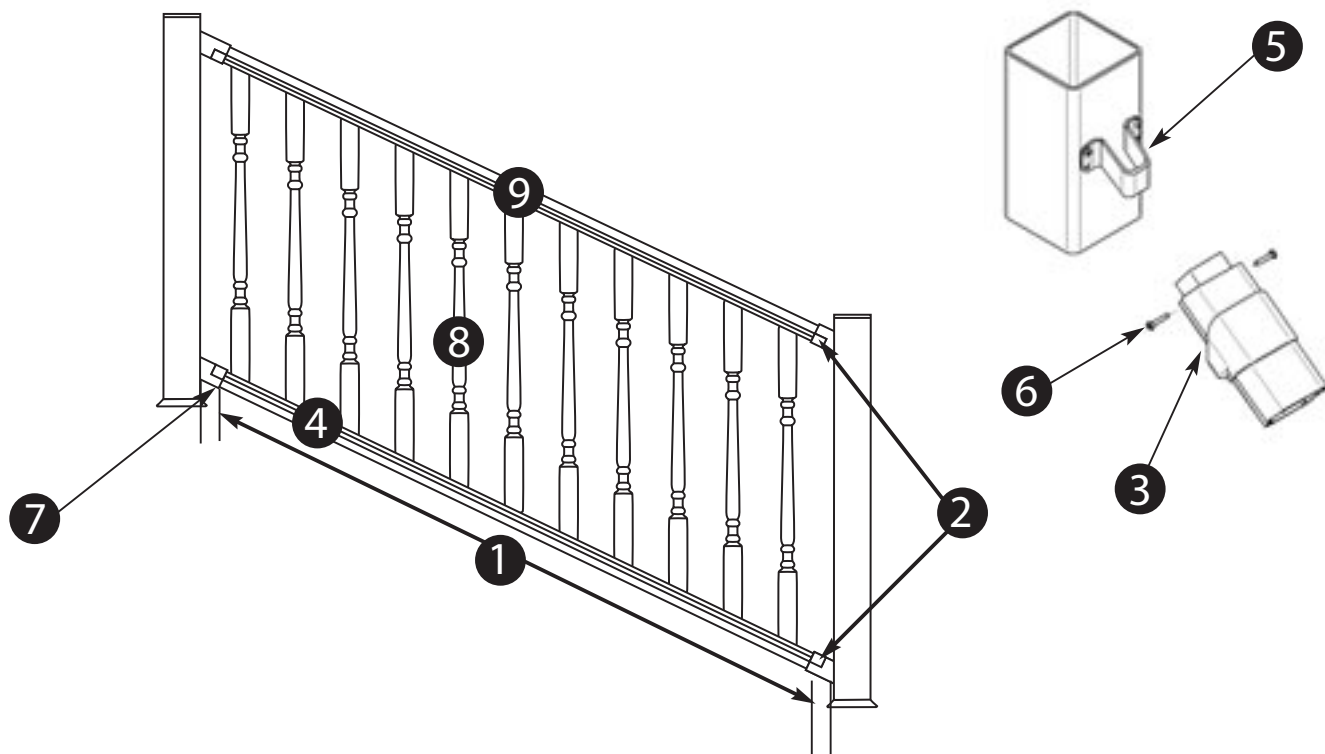

**Step 1:** Check for equal baluster spacing at posts.

**Step 2:** Mark rail where it meets the post. Square top rail to bottom rail, measure back 1/4" from the mark and cut rails.

**Step 3:** Transfer stair angles to covers and cut. Slide vinyl covers over ends of bottom rail. Insert aluminum brackets into both ends of rail.

**Step 4:** Position bottom rail between posts.

**Step 5:** To secure aluminum bracket to posts with screws provided (two screws per aluminum bracket) on the TOP rail, place screws in the bottom holes of the bracket. In the BOTTOM rail, place screws in the top holes of the bracket. Slide vinyl covers to posts.

**Step 6:** Secure rail to aluminum brackets with 1" screw (provided) through flat side of rail. (Tip: Pre drilling rail and bracket will enhance application. Use a 9/64" drill bit).

**Step 7:** Slide vinyl cover to post and fasten to rail with vinyl adhesive.

**Step 8:** Insert baluster into bottom rail.

**Step 9:** Install top rail and repeat steps 5-7.

Note - the 1-1/2" x 1-1/2" Keystone square baluster must measure 32-1/2" for stair applications. You can field cut a 1-1/2" x 1-1/2" x 33-1/4" square baluster to 32-1/2" (cut 3/4" from end) for this use. The 1-1/2" x 1-1/2" x 33-1/4" Keystone traditional baluster works for both flat and stair applications.



2525 WALDEN AVENUE, BUFFALO, NY 14225  
 PHONE: 800-333-0569 FAX: 716-685-1172  
<http://www.bufftech.com>